

FISH FRIENDLY PUMPS

SAF/SBF RANGE

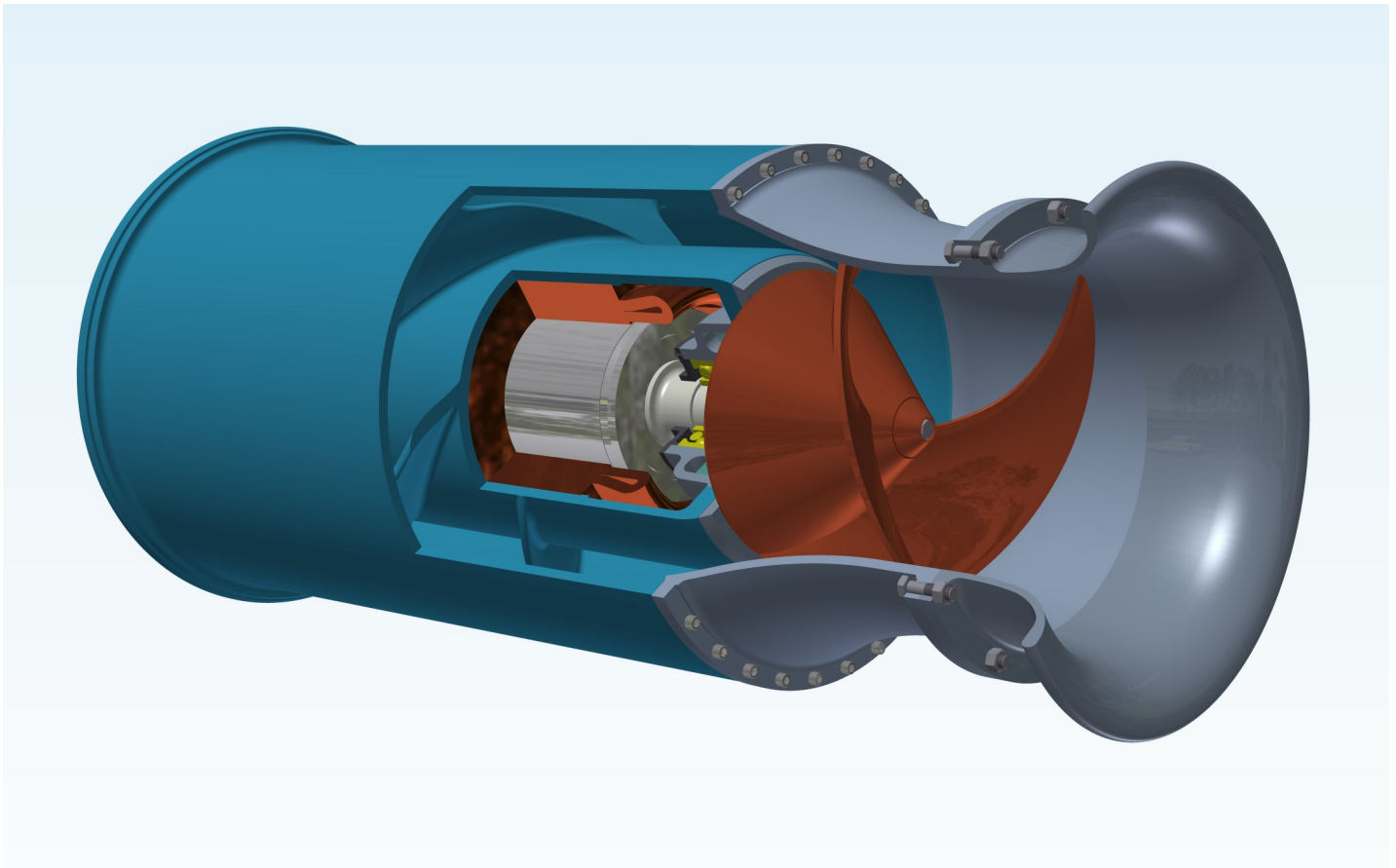

TYPICAL APPLICATIONS

- **Land Drainage**
- **Surface & Storm Water**
- **Flood Defence**
- **River Abstraction**
- **Fish Farms**
- **Return Activated Sludge**

Bedford Pumps' submersible range of Fish Friendly axial and bowl pumps cover from 400 to 9,000 litres per second at 2m to 14m head.

Larger capacity pumps can also be designed to meet specific requirements.



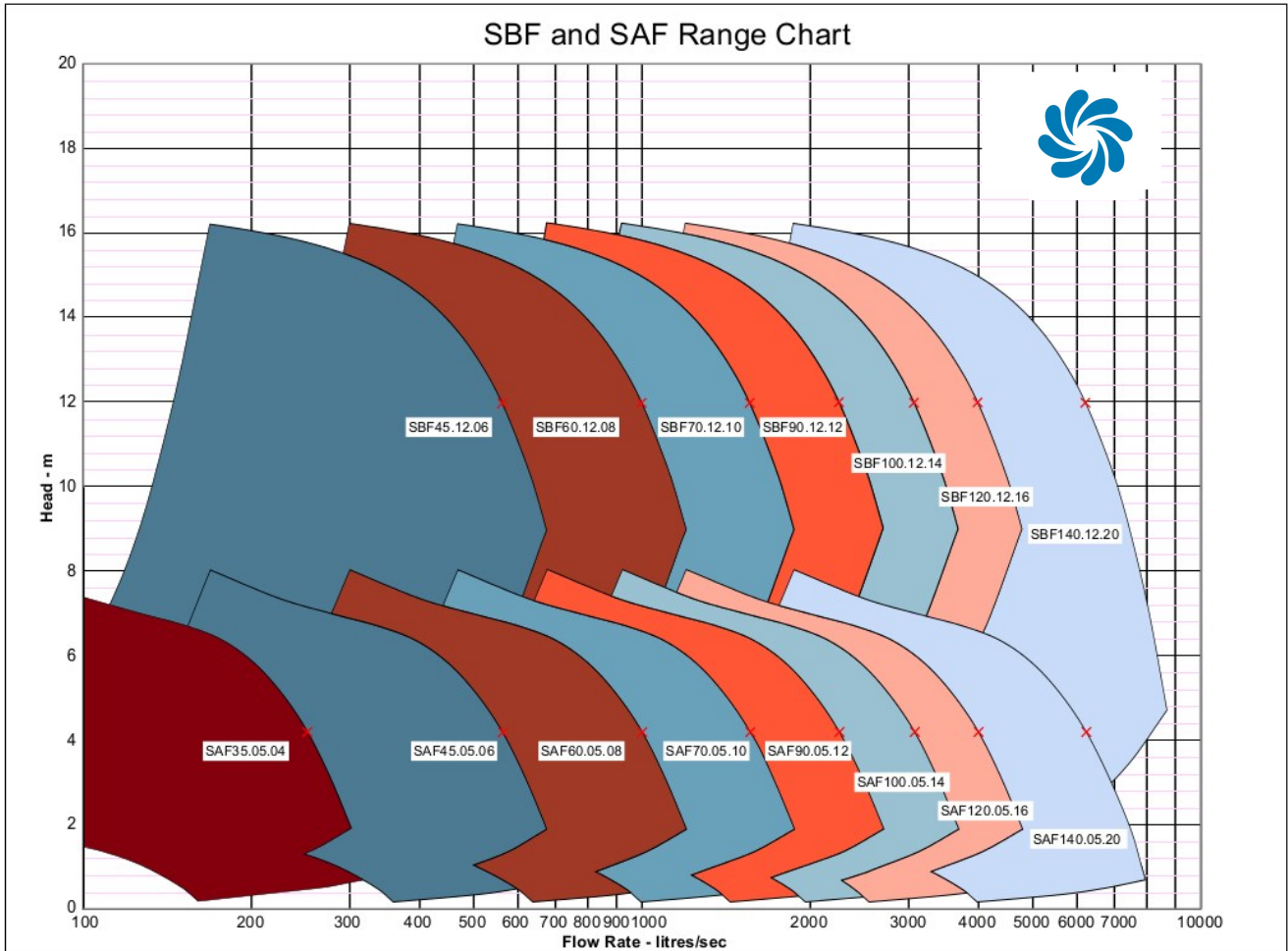

Cable

Heavy duty trailing flexible rubber cable to BS 7919. Optional symmetrical cable for variable speed applications or WRAS approved cable for potable water applications. Other cable types available on request.

Terminal Box

High integrity IP68 profiled design. Easy access to terminal plate without removing cables. Design to EN50019 (EEEx) for where applicable.

Motor

Conventional dry wound, squirrel cage, high efficiency, induction motor designed to BS4999, BS EN 60034 where applicable with Class F insulation. The motor is contained within an IP68 motor casing. Suitable for Star Delta D.O.L., Auto-Transformer or Inverter starting. Motor enclosures designed to EN 50018 (EEExd) available where applicable. Electrical supply 380-440V, 3.3 kV or 6.6 kV 50Hz or 60Hz.

Instrumentation

Each pump is supplied with a Bedford Pumps Condition Monitor as standard. This "free issue" instrument records and displays:-

- Barrier oil condition which enables the health of the primary seal to be analysed
- Secondary seal failure detection (trip)
- Thrust and journal bearing temperature indication (alarm and trip)
- Motor winding temperature (alarm and trip)

Bearings

Grease lubricated, angular contact thrust and deep ball groove journal bearings packed for life. Typical design life 50,000 hours. Insulated bearings provided on inverter driven motors

Pump Casing

Solid cast construction with streamlined guide vanes designed to optimise pump efficiency and minimise fish damage. Standard material to Cast Iron BS EN 1561/EN-GLJ-250 with alternatives available on request.

Mechanical Seals

Two high quality, independently mounted, mechanical seals in an oil-filled enclosure to prevent water ingress into the motor. The barrier oil can be supplied to WRAS approval for potable water and environmentally sensitive installations.

Impeller

High efficiency open bladed design of solid cast construction. Blade profile optimised to prevent fish/eel damage. Statically & dynamically balanced prior to assembly. Standard material Aluminium Bronze BS EN 1982 CC333G

Bellmouth

Low loss, high efficiency bellmouth entry with optimised velocity profile. Generally Cast Iron to BS EN 1561 / EN-GJL-250 with alternatives available on request.

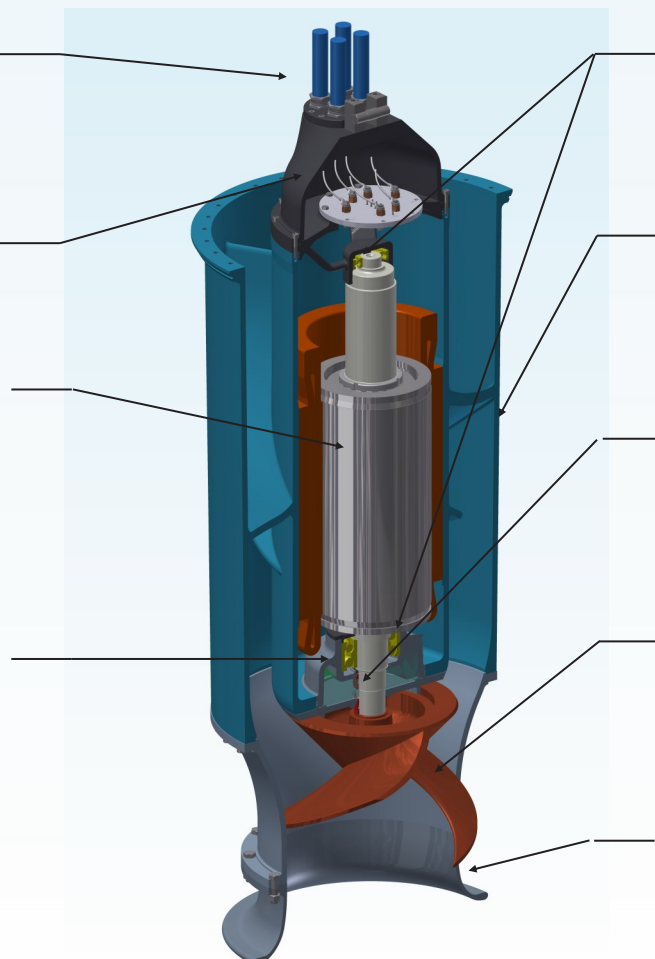

TYPICAL SUBMERSIBLE ARRANGEMENTS

Figure 1
Wet Well
Foot Mounted

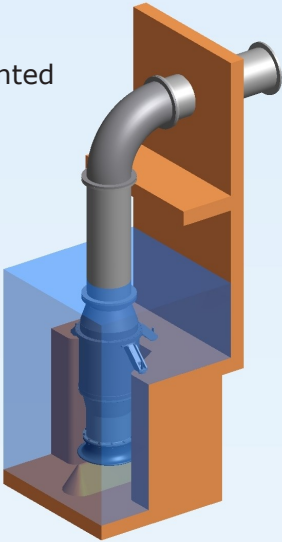

Figure 2
Wet Well
Suspended

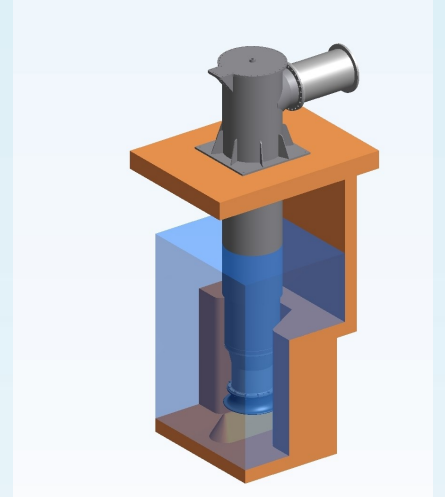
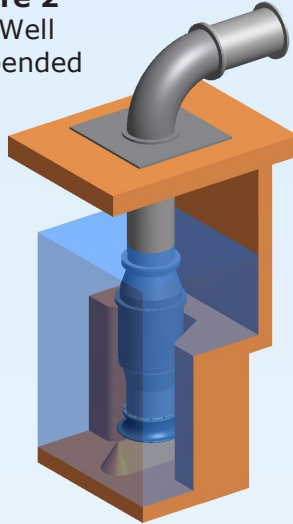

Figure 3
Wet Well Canister
Above Floor Discharge

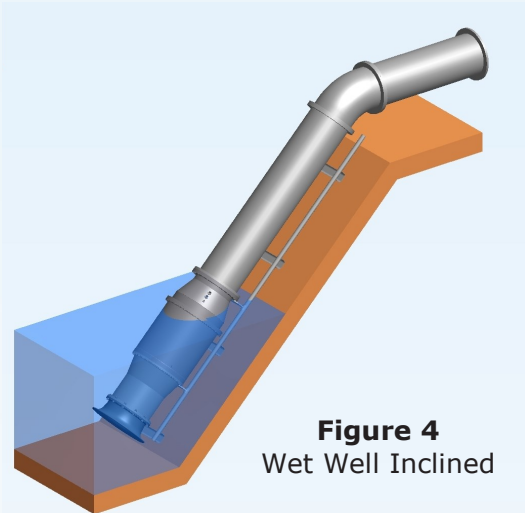

Figure 4
Wet Well Inclined

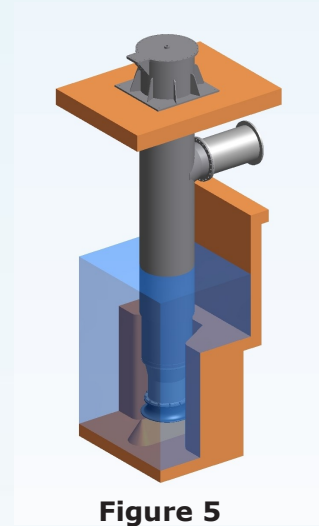

Figure 5
Wet Well Canister
Below Floor Discharge

Figure 6
Wet Well Canister
Cascade Discharge

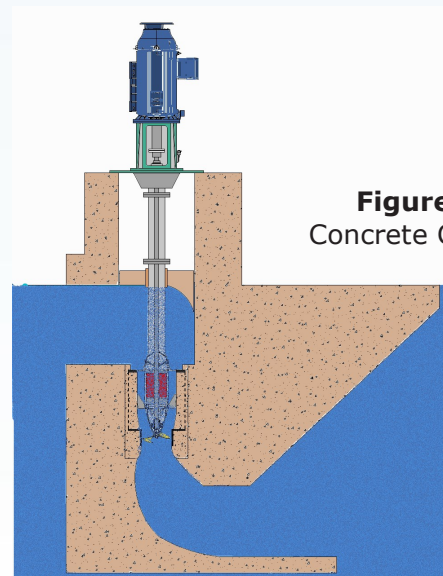
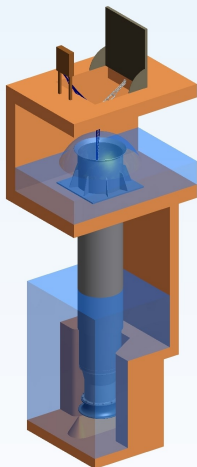

Figure 7
Concrete Casing



Bedford Pumps are one of Europe's leading manufacturers of large submersible and conventional pumps to the water and wastewater industries



BEDFORD PUMPS LTD.



SAF SBF 09-2018

Bedford Pumps Ltd. Brooklands, Woburn Road Industrial Estate, Kempston, Beds, MK42 7UH. United Kingdom
Tel: +44 (0) 1234 852071 Fax: +44 (0) 1234 856620 Email: sales@bedfordpumps.co.uk Website: www.bedfordpumps.co.uk